

# Aluminium Smelter Basement Cleaner

ett.com



**PROVEN PERFORMANCE  
RELIABILITY AND  
DURABILITY**

**650 mm  
Height**

Special vehicle solutions for Mining and Industry

# Purpose Designed

Ease of operation



## Machine Design

The ETT Aluminium Smelter Basement Cleaner (ASBC) is designed from the ground up to operate efficiently in the demanding environment of the pot-line basement.

The low profile design and intuitive remote control system allows the operator to effortlessly navigate the basement tunnels and remove alumina dust falloff.



## Ultra Low Profile

At a height of only 650 mm, the skid-steer can operate comfortably in confined spaces where headroom is limited. The machine is specifically designed to operate under the pot-line and remove alumina dust where it collects over time.

# Intuitive Remote Control

## Enhanced operator safety

### Remote Control

The ETT low profile skid-steer is equipped with a robust remote control system. The controller allows for precise control over the vehicle at all times, ensuring efficient and safe operation. The joystick interface is intuitive and responsive, allowing the operator to precisely manoeuvre the machine in confined spaces.

### Engine Anti-Stall

The incorporated engine anti-stall software makes it impossible for the engine to stall during operation. This further ensures that the machine can't stall in a hazardous area where it might be difficult to recover.



### Fast Commute Function

The machine includes a fast commute function for traveling longer distances quickly. The fast commute function is manually activated on the remote controller, after which the machine will travel slightly faster than walking speed, when traveling forwards. The fast commute function applies only to forward motion, and is automatically disabled if any bucket or load-arm functions are moved.



### DIESEL ENGINE

The remote skid steer loader utilises a reliable 13 kW Yanmar 3 cylinder diesel engine. The efficient diesel engine allows for longer operating hours compared to equivalent battery powered machines.

# Robust Systems

## Reliable Operation

### Dust Proof

The ASBC is specifically designed to operate in the hazardous work environments of an aluminium smelter. All systems and components are sealed and protected against the highly abrasive alumina dust. Extra care has been taken to ensure that the fuel, engine oil and hydraulic oil systems are protected against any contamination.

- Filling of diesel, engine oil and hydraulic oil is performed via on-board filters.
- Engine oil evacuation is performed through a quick coupler.
- The engine oil dipstick is replaced by an oil level sight glass.
- The engine oil filler cap is sealed off.
- The engine is fitted with a high capacity air cleaner and matched pre-cleaner and safety element.



### Magnetic Field Shielded

To operate in close proximity to strong fields, the basement cleaner chassis is constructed from heavy gauge steel to shield the internal electronics and control systems from any electromagnetic interference. The base machine can operate reliably in magnetic fields up to 400 gauss.

### Optional Mag-Shield added protection

The optional Mag-Shield added protection package provides additional shielding against up to 600 gauss magnetic fields.



# Durable Drivetrain

## Intelligent monitoring

### Integrated Safety Systems

The intelligent on-board control systems provide several automatic safety systems that ensure the reliable and safe operation of the machine.

- Automatic engine shutdown with loss of radio signal.
- Engine shutdown on loss of oil pressure.
- Warning on remote controller for:
  - Alternator charge failure.
  - High coolant temperature.
  - Low hydraulic oil level.
- Emergency shut off button on machine and remote control.



### Robust Systems

The loader is designed to operate in hazardous environments where external factors would interfere with less robust equipment. Integrated into the machine is the ETT CAN bus system. The CAN bus control provides superior reliability and is highly resistant to heat, dust and strong electromagnetic fields.

### Drivetrain Features

- **Integrated Load Sensing** – The machine evenly distributes power to the drivetrain and the lifting hydraulics to allow all functions to be worked at the same time without overloading the engine. This allows fluid and efficient movement of the machine, thus significantly improving productivity.
- **Integrated System Monitoring** – All vital systems on the machine are monitored by the control system and feedback is provided to the operator only when parameters reach a set threshold.
- **Integrated System Protection** - The operator is informed by visual and audible prompts that a system requires attention. Should the operator not respond in a certain time, the control system goes into a self-protection mode where power and speed is reduced to protect the systems. The operator is then able to drive the machine out of the work area in this mode to allow inspection and correction of the condition causing the alarm.

### Maintenance Accessibility

The ETT basement cleaner is designed with excellent maintenance accessibility due to the carefully laid out interior. The entire top of the machine is opened, providing unrestricted access for servicing. All interior components are also positioned and spaced so that technicians can fit their tools and replace componentry without having to remove several components above.

### Cleaning

All components are sealed and electronics are IP65 rated. The exterior and interior of the machine can be hosed down for easy cleaning and removal of abrasive alumina dust. The radiator and oil coolers are nested together and can be hosed down for easy cleaning.



# Servicing Convenience

## Portable fueling and oil change equipment

### Refuelling

The machine is refuelled using the included ETT portable electric fuel pump. The electric pump connects to the skid-steer battery through an external power connector. The fuel line then connects to the external fuel coupling, ensuring no debris can contaminate the fuel during the filling process.



### Engine Oil Replacement

The included ETT oil service trolley simplifies the engine oil change procedure significantly. The waste oil is drained through a suction hose, and new oil is pumped into the engine with the on-board electric oil pump. The electric pump draws power from the skid-steer battery through an external power connector. The oil filling line connects to a sealed coupling, ensuring no debris contaminates the oil.



### CAMERA OPTION

- Optional forward facing fpv camera with live remote feed.
- Optional reverse facing fpv camera with live remote feed.
- Allows safe operation in basements and tunnels where direct line of sight is not always possible.
- Allows for remote inspection of hazardous areas.

# Dimensions

650-W

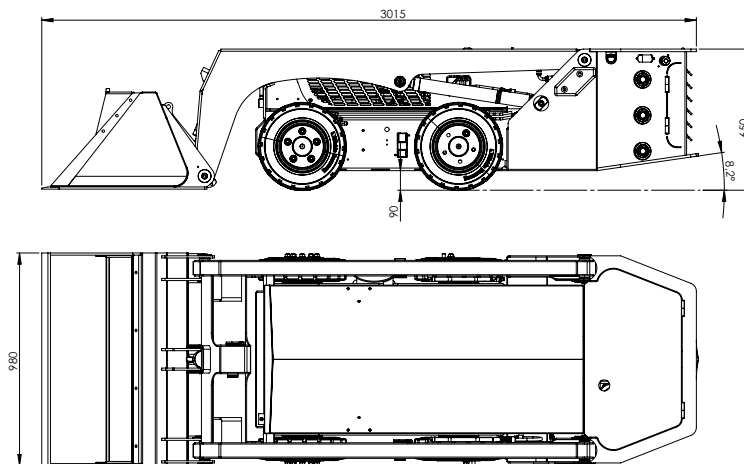

1 121 kg



# INNOVATIVE, EFFICIENT & DURABLE MACHINERY

ett.com



**ETT** maintains a complete inventory of repair and maintenance parts for all our products. This includes accessory kits and service parts packages.

We are committed to providing world class parts availability and technical support .

Our team of engineers and support staff are committed and focused on ensuring your asset's performance and ultimately your satisfaction with ETT products.

## **Company**

ETT is a leader in the field of innovation, design and manufacturing of specialised mobile equipment for Mining and Industry. Our solutions are aimed at improving productivity and safety and are currently deployed in over twenty countries around the world.

## **Customer Focus**

It is our mission to always put the needs of our customers first. We achieve this by listening to, and clearly understanding our customer's needs, before initiating the process of developing or engineering a solution that exceeds our customers' expectations.

**phone**  
**+27 37 751 1630**

**mail**  
**info@ett.com**

**web**  
**www.ett.com**



 **ENGINEERING  
TOP TECH Co**

Special vehicle solutions for Mining and Industry